

SMART TECHNOLOGY,
TIMELESS DESIGN

Glass Push-button

HmIP-WGS | HmIP-WGS-A

The Homematic IP Glass Push-button with touch surfaces is characterised by its contemporary design in a 55 mm frame and can be integrated perfectly into anyone's living environment. You can configure the glass push-button as either a 1-, 2- or 4 channel button. Depending on the configuration, the touch surfaces are separated visually from each other by separators.



Frame not included in the scope of supply

homematic ^{IP}
Smart living, simply comfortable

ELEGANCE IN GLASS

The elegance of the surface, made of durable and hygienic glass, immediately catches the eye. In combination with a matching glass frame (available separately), the device fits stylishly into high-class interiors and enhances the appearance of any room.

THE RIGHT FUNCTION FOR EVERY APPLICATION

Up to four configurable channels enable users to control multiple devices and system functions in their smart home conveniently with the touch of a button.

The Quick Action function (simultaneous touching of all touch surfaces) can also be used for a quick operation, e.g. for switching the ceiling light.

SMART IN THE BACKGROUND

When the Glass Push-button is in 2-channel or 4-channel mode, the separators automatically go dark. When touched, they provide a visual feedback and light up. The backlighting can have a fixed brightness or can be controlled by a timer profile.

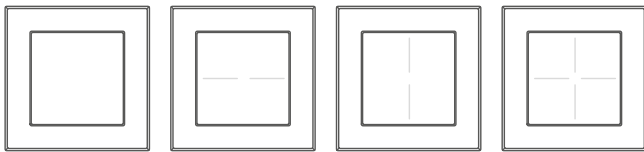

Configuration of the push-button layout

MODULAR DESIGN

Thanks to its flexibly combinable design, the Glass Push-button can be integrated into existing switch series (with 55 mm frames) from the most popular manufacturers (an overview of compatible manufacturers is listed at www.homematic-ip.com).

Operation requires a connection to a Homematic IP Access Point or a Central Control Unit.

TECHNICAL SPECIFICATIONS

Supply voltage	230 V/50 Hz
Max. switching capacity	6 A 1380 W
Degree of protection	IP20
Load type	Ohmic load
Cable type and cross section	Rigid and flexible cable 0.75 – 2.5 mm ² Only in switch boxes (device boxes) in accordance with DIN 49073-1, only in Legrand Batibox switch boxes
Installation	
Ambient temperature	5 - 35°C
Dimensions (W x H x D)	
HmIP-MMR:	71 x 71 x 36 mm
HmIP-WGS-F:	54.5 x 54.5 x 29 mm
Weight	113 g
Radio frequency band	868.0-868.6 MHz 869.4-869.65 MHz
Typical Open area RF range	130 m

EASY TO INSTALL

The Homematic IP Mounting Module with switching output (HmIP-MMR), installed in a switch box, is used as the base for the Glass Push-button. The mounting module also features a relay output and an extension input for setting up button circuits.

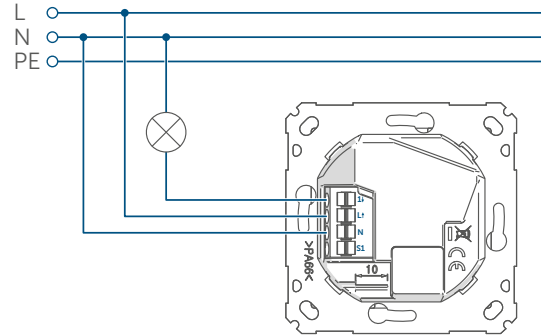

Connection without extension

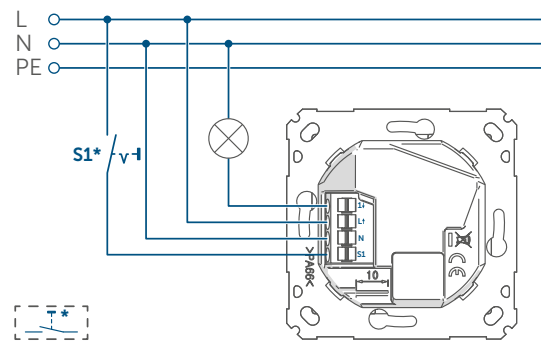

Connection with extension

FLEXIBLE OPERATION

- ✓ Directly via the touch surfaces
- ✓ Wirelessly using Homematic IP push-buttons, or remote controls or motion detectors
- ✓ At any time via the Homematic IP app
- ✓ Via adjustable time profiles to automatic switch the lighting on or off at the desired time
- ✓ Easy operation via voice control (using Amazon Alexa or Google Assistant)

LOGISTICS DATA

Version	White	Black
Product reference	161160A0	161170A0
EAN code	4047976611607	4047976611706
Short description	HmIP-WGS	HmIP-WGS-A
Packing unit	60	60
Packaging dimensions	122 x 112 x 73 mm	122 x 112 x 73 mm
Weight incl. packaging	229.6 g	229.6 g

PACKAGE CONTENTS

Glass push-button, front
Mounting module with relay
Mounting accessories
Operating manual